

APPROVED FOR PRODUCTION
 2013/7/17 RFL

REV 更改号	DATE 日期	REVISION DETAILS 更改内容	APPD 审核并批准
A	2017.07.13.	Production issue	

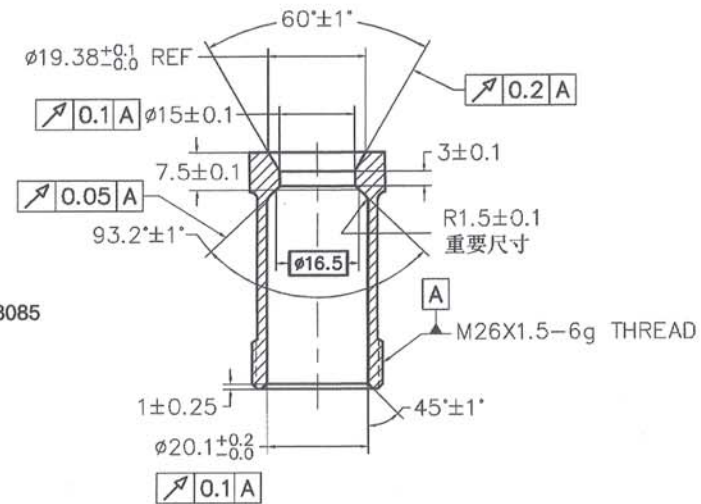
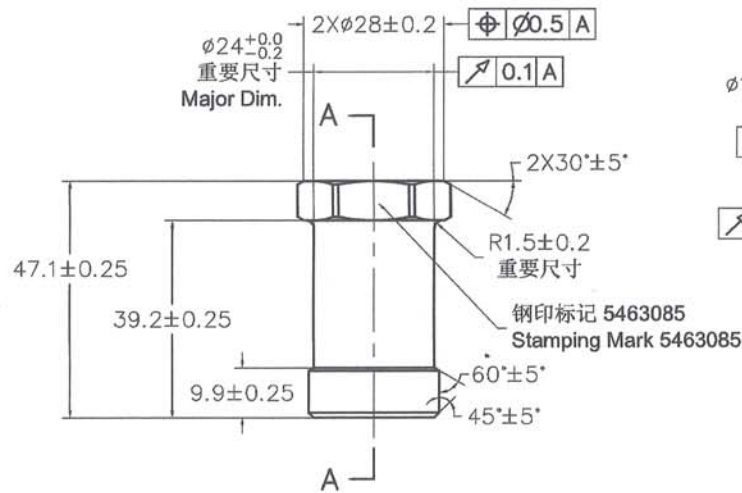
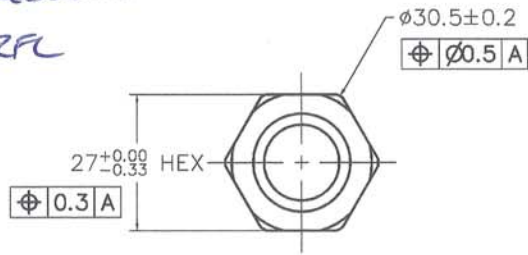

SECTION A-A

UNLESS SPECIFIED
 ALL DIMENSIONS IN mm,
 MACHINED SURFACES Ra=3.2um,
 ANGLE TOLERANCES ±1°,
 Other tolerance except angles,
 in accordance with
 GB/T1804-2000(ISO2768-1)-m
 and GB/T1184-1996(ISO2768-2)-m

其它事项,
 图示尺寸单位为mm,
 未注机加工表面粗糙度 Ra=3.2um,
 未注角度公差 ±1° ,
 其它未注公差 (除角度外) 均按:
 GB/T1804-2000 (ISO2768-1)-m 和
 GB/T1184-1996 (ISO2768-2)-m

交货时零件须达到机械性能等级10.9级 (按紧固件分类标准),
 抗拉强度为1000MPa, 硬度达到HRC38-44.

Property class of 10.9(As per the standard classification for the threaded fasteners
 with a tensile strength of 1000MPa and HRC38-44.

Yuhuan Getal Machinery Co.,Ltd			
PART No 零件名	41265-M26-TN		
SCALE:	APPD: 批准 Zhang	DRN: 制图	Panda 2017.07.11
NTS	DATE: 日期 13/07/17	CHK: 审核	Panda 2017.07.11

MATERIAL Chinese steel 42CrMo

FINISH

Remove all sharp edges,burrs,slivers and swarf, break all edges 0.127-0.254mm.
 ZINC PLATING WITH 12um MICRONS MINIMUM PLATING THICKNESS AND TRIVALENT CHROMATE PASSIVATION AND WITHSTAND 96 HRS TO WHITEH4S TO RED RUST IN SALT SPRAY TEST.

去除所有毛刺, 铁屑等残留物, 锐边倒钝0.127-0.254mm.
 镀锌, 三价铬钝化, 银白色, 盐雾试验96小时无白锈, 144小时无红锈, 镀锌层大于12um.